



Dishwashing

EVO Generation - Concept

DISHWASHER CO-112 B DD

DIMENSIONS

		<u>Article</u>	<u>Packed</u>
Length	mm	658,00	700,00
Depth	mm	756,00	840,00
Height	mm	1.554,00	2.040,00
Weigth	Kg	145,00	166,00
Volumen	m3	0,77	1,20

ELECTRICITY

<u>Electric power</u>	KW	
230V -1+N		11,10
230V - III		2x16+T - 63 A
400V - III+N		3x6+T - 40 A
		4x2,5+T - 25 A

WATER

Water consumption (lit/h)	144,00
Pressure (Kg/cm2)	2 ÷ 4

GAS

Not used

STEAM

Not used

AIR

Not used

LEVEL SOUND

(dB) **63,00**

DISHWASHER CO-112 B DD

Hood type dishwasher - EVO Generation - Concept range.
 Hourly production: 40 baskets/hour - 720 dishes/hour.
 Clearance (max ware height): 440 mm.
 Electronic control.
 Wash cycles: 90" - 180".

Made of stainless steel.
 Counterbalanced hood.
 Double rotating wash and rinse systems, made of AISI-304 stainless steel.
 Wash pump, 600 W each.
 Drain pump: 70 W. Drainage cycle.
 Tank with 4.5 kW heating power.
 Tank capacity: 34 litres.
 Boiler heating power: 6 kW.
 Boiler capacity: 9 litres.
 Water consumption: 2.4 litres/rinse.
 Thermostatic temperature control: washing at 60°C and rinsing at 90°C.
 Thermostat.
 Safety thermostats.
 Built-in automatic rinse dispenser and detergent doser.
 Built-in non-return valve.
 Safety magnetic switch for hood opening.
 Adjustable legs.
 Water protection rating: IPX4
 Total power: 6.60 / 11,1 kW.
 Dimensions: 658 x 756 x 1540 mm.

Baskets equipment: 1 x CT-10, 1 x CP-16/18 and 2 cutlery containers.

Connections points	X	Y	Z	Diameter	Information
ELECTRICITY	210	50	65		
SOFT COLD WATER	305	50	65	3/4"	
DRAIN	370	50	65	30 x 25	

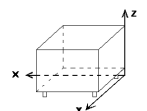

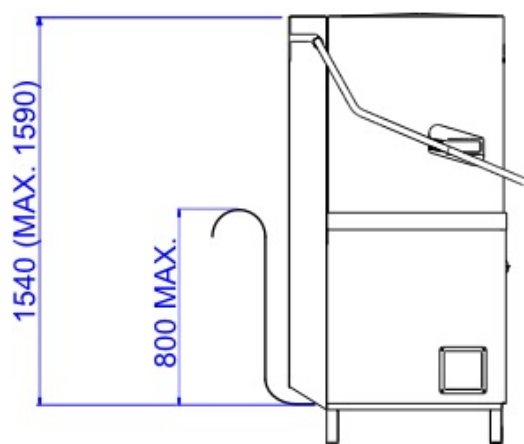
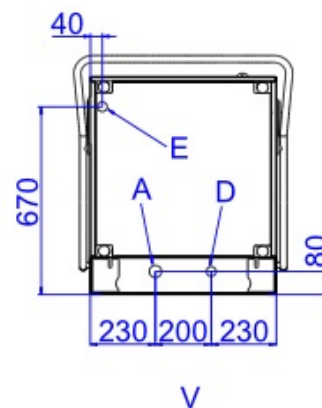
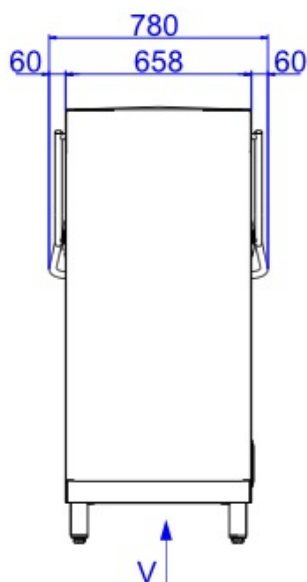
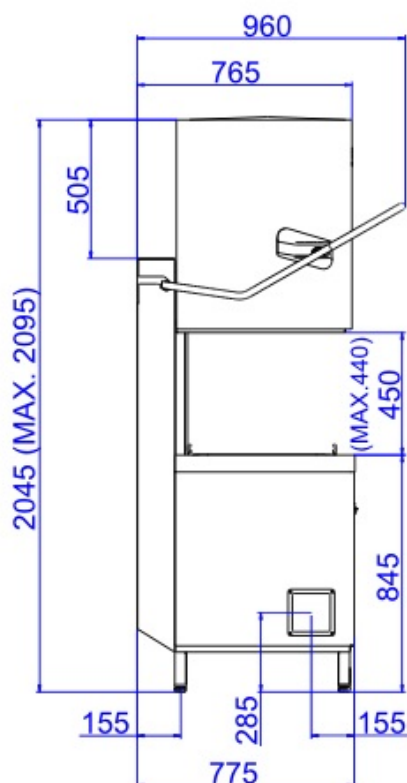

A: ENTRADA DE AGUA
E: ALIMENTACIÓN ELÉCTRICA
D: DESAGÜE

A: WATER INLET
E: ELECTRICAL CONNECTION
D: DRAIN

A: ARRIVÉE D'EAU
E: CONNEXION ÉLECTRIQUE
D: VIDANGE